

The Colonial Woodcutter

The Newsletter of the Annapolis Woodworkers Guild

Meeting 7:00 PM August 14th, Davidsonville United Methodist Church



AUGUST MEETING
ANNUAL TOOL SWAP

August 2025

Contents

August 2025 President's Message.....	3
August Monthly Meeting.....	4
July Meeting	4
July Speaker	5
Show and Tell.....	6
July Raffle Winners	11
Quiet Waters Exhibition and Sale.....	12
Woodworking Opportunity - Help Needed	13
Busch Annapolis Library Hobby Fair	15
Tip of the Month.....	16
One on One Skills Classes and Instructors.....	17
AWG Member Mentors	18
AWG Officers	19
AWG's Supporting Vendors	20

Newsletter Submissions

If you have new projects, tools or fixtures that may interest to others, or if you have found a wood related news story, please share them with the Guild. Send a description, with pictures if possible, for inclusion in the Colonial Woodcutter to the editor, Duncan Adams at duncanladams@gmail.com. Items submitted by the first Thursday of the month will be published.

Many thanks to those who contributed to this month's issue.

August 2025 President's Message

Dear fellow members,

As you know, there will not be a general meeting in August. Instead, we will hold our annual tool swap at 7pm on Thursday, August 14th in the parking lot of Davidsonville United Methodist Church. It will be held rain or shine. Bring tools you want to swap or sell. Or bring your wallet and buy a tool you need. Or, just stop by to socialize with your fellow woodworkers! Jim Cowan and I will bring the leftover 2x4's if you would like to buy one for your 2x4 project.



I recently enjoyed a nice vacation in New Hampshire and Maine, and am back into my routine of yard work, volunteer work, and spending time with my granddaughters. I plan to make time for some woodworking too! In addition to a possible 2x4 project, I want to make an ornament for the Christmas party, and a couple items for the AWG table at the Quiet Waters Park Holiday Artisan Market this winter, and some Christmas gifts for family members. I invite you to also start thinking about your projects. If you have anything extra sitting around now, or something you plan to make for the Artisan Market, plan to bring them to the AWG general meetings this fall (September, October, November). Or, you can drop them off at my house in Pasadena, or by the toy workshop in Severna Park on Monday mornings.

A few dates for you to put on your calendar:

- August 14 is the tool swap
- Sep 11, Oct 9, Nov 13 General Meetings: bring your items for the Artisan Market
- November 13 is the judging of the 2x4 contest; bring your project to the room just outside of the back of our meeting room by 650pm
- December 11 is our Christmas party (remember to make an ornament)

Be safe during your summer travels. And remember to stay hydrated.

Ann

annsentinella@gmail.com; 443-742-7037

August Monthly Meeting

**Thursday, August 14th, 2024, 7:00PM
Davidsonville United Methodist Church
819 W Central Ave, Davidsonville, MD 21035**

Please join us for our monthly meeting of the Guild. The August meeting is the annual Guild tool swap. Bring any tools that you no longer need and find some new ones that you just can't live without.

July Meeting

President Ann Sentinella opened the meeting and presented the members with news in several areas. She said that efforts are underway to update and improve the Guild's web site and communication generally. She reminded the Guild about the exhibition and sale at Quiet Waters Park during the holiday season (see article below for details).

A second cutting board class at the Annapolis Makerspace is being planned, though the date has not been set at this time. In addition, Tony Aquilino at the Makerspace is planning a repeat of their CNC router tutorial – date also pending. Guild member Paul Hansen is planning to initiate a series of box classes at the Makerspace for their members and ours.

On the subject of education, Ann touched on several areas. First, she pointed to the recent video made by Chris Desautels and posted to YouTube, urging other to follow the example. Second, she has designated the meeting in October 2025 as a "Learning Meeting," in which the first half of the will feature 10 to 20 minute skills presentations by members.

You are all encouraged to consider participating. If successful, this could become a bi-annual event.

Ann urged members to offer hands on classes – like the box, intarsia and inlay classes presented in the last few years. She passed around a sign-up sheet.

Finally, Ann appealed for volunteers to fill the positions of Program Chair and Outreach.



July Speaker Dwayne Vogel



Dwayne Vogel, owner and operator of Bullock's Furniture Restoration in Odenton, is an experienced repairer and refinisher of furniture. He presented his thoughts on several aspects of restoration. For disassembly, he recommends white vinegar to loosen PVA glue joints and advises that heat should only be used with caution due to the risk of scorching the wood. Joints with epoxy or CA glue can only be disassembled by cutting and rebuilding. Bullock's uses PVA glue for assembly in most cases and only uses hide glue when customers specifically require it.

Dwayne discussed finish removal and the variety of solvents used to strip finishes with a range of effectiveness and toxicities. He is also a proponent of mechanical stripping with sandpaper or scrapers.

Dwayne's thoughts on finish include use of Zinsser shellac based, wax free sanding sealer as a barrier coat when refinishing. For final coat Bullock's prefers two coats of pre-catalyzed lacquer.



Show and Tell



Ken Gilmore made this maple rocker and two level step stool for his grandchildren.

The finish is Arm-R-Seal



Rodger Young turned a replacement shade for a gooseneck lamp from elm. He finished it with super glue and a top coat of Osmo. He brought along the new end grain bowl gouge from Henry Taylor that he used to make it.





Joe Epperson made a series of cookbook/iPad stands for his wife. Evolving requirements led to a variety of designs.

Harry Chavez scroll sawed this piece representing his new band.



Claire Cole's grandson Fred and his brother showed off the tug boat that they made.



David Furlong made about a hundred band saw horses to support a girls' camp art activity. He cut the horses from 2x4's and the girls painted them.

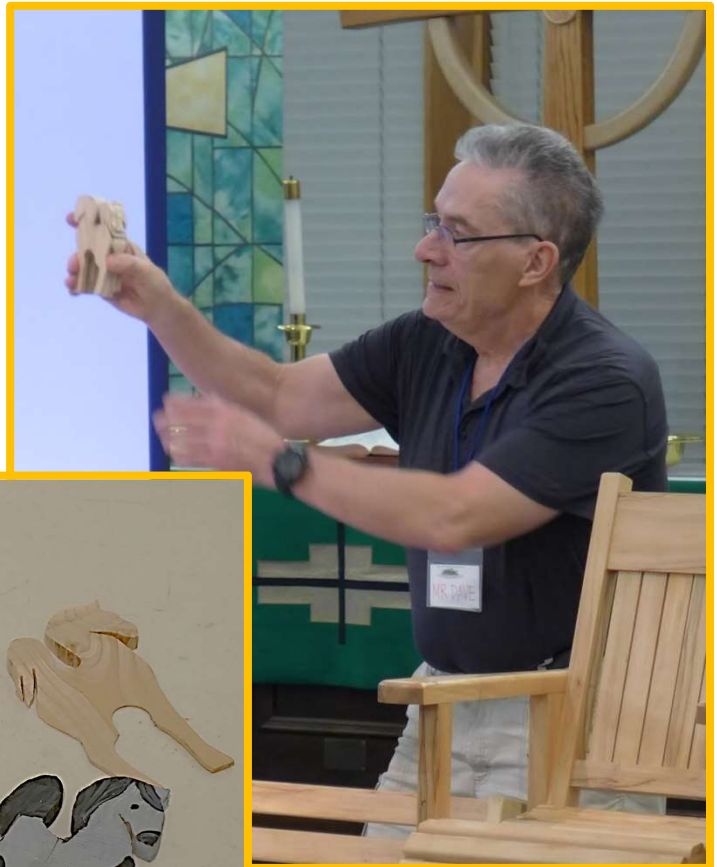

Annapolis Makerspace

Need shop space?
Do you enjoy learning?
Want to meet other people like you?

Tools Available: Mitre Saw, Drill Press, Table Saw, Spindle Sander, Drum Sander, Band Saw, 20" Planer, Joiner, Various Hand Tools, 4x8ft CNC ShopSaber CNC Router, 100W CO Laser Cutter, 3D Printers, Cricut, SailRite Sewing Machine

Want to learn more?
Visit our website at:
www.MakeAnnapolis.org

Join Today!

 facebook.com/AnnapolisMakerspace
 [@annapolismakers](https://twitter.com/annapolismakers)

24 / 7 access is only \$65 per month

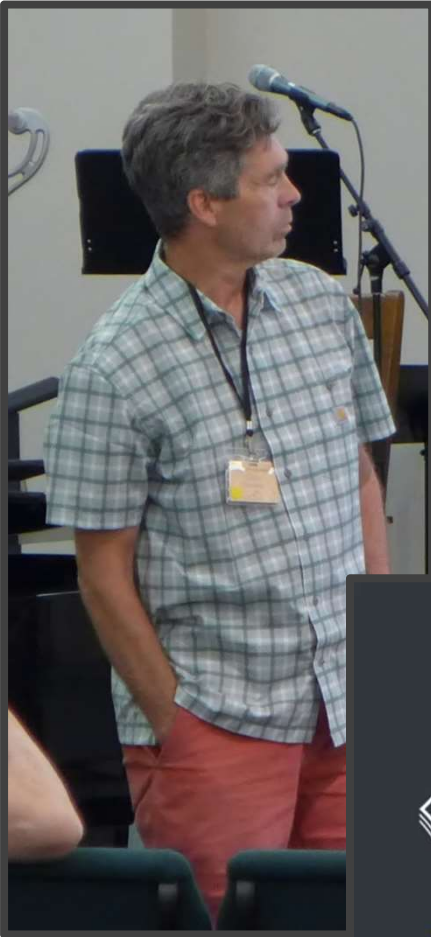

First vice president Chris Bucknall presented the safety brief on the subject of hearing protection – particularly regarding use of ear plugs. He showed a video on the proper techniques for inserting reusable and disposable ear plugs. A link to the video is below.

<https://www.youtube.com/watch?v=O2p4-mRfdvc>



July Raffle Winners

Paul Dodson conducted the monthly raffle, with Phil Christenson drawing the first winner.

All the winners are pictured below.

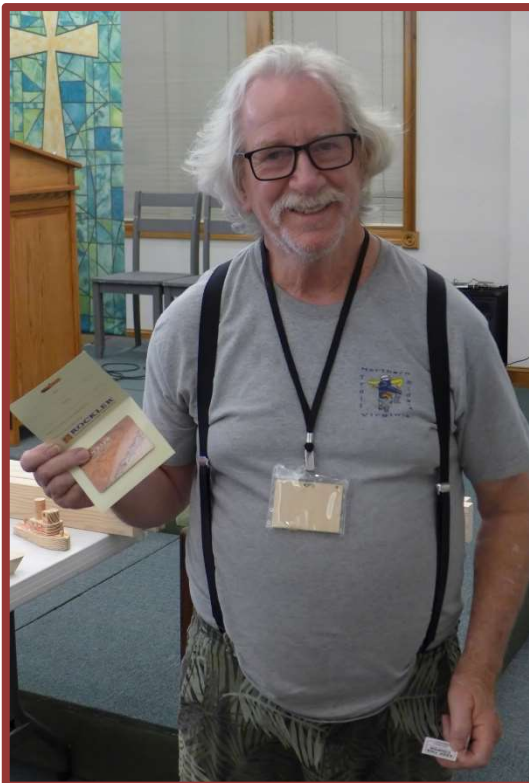

Joe Epperson
\$50 Rockler Gift Card



William Doyen
Bowl Sanding Set



Nick Jedrich
Two Push Blocks

Quiet Waters Exhibition and Sale

The Fine Arts Committee of the Galleries at Quiet Waters Park has invited the Annapolis Woodworkers Guild to participate in their Holiday Artisan Market XIV, Exhibition/Sale. This invitational holiday event will take place in the Willow Gallery at Quiet Waters Park in Annapolis from November 19, 2025 – January 4, 2026. A reception will be held in the Galleries on Sunday, November 23, from 1:30 – 3:30 p.m. Food and beverages will be provided by the Fine Arts Committee.



AWG will pay a fee of \$50.00 which will cover gallery space, liquor license, and publicity. 25% of sales will support the Friends of Quiet Waters Park in their mission to maintain and enhance our local county park. The Guild can bring 25-35 pieces of work which will then be intermixed with the work of other artisans to present a pleasing, boutique-style display. This is a browse-and-buy show (purchased items will be taken at the time of sale). The sale is staffed by volunteers for the Quiet Waters Fine Arts Committee so the artisan is not expected to be present through the fair which will be open daily for the duration of November 19, 2025 through January 4, 2026.



The artisan will price their items themselves and the Quiet Waters Committee keeps 25% of the proceeds, 25% goes to the AWG and the remaining 50% to the artist. Unsold items will be returned to the artist at the conclusion of the Market.

Items you wish to include in the sale can be brought to the October or November meeting and must be clearly marked with the artist's name, phone number and price for their item (considering the sale price split outlined above). Ann will discuss this event at the next meeting. Feel free to bring any questions or concerns to the meeting, Ann or the board. Detailed instructions are below.

1. Large pieces are fine as long as they can sit on a pedestal/plinth. We have a few available, but might be better to bring something to place the pieces on
2. There will be a tally of each person's items sold
3. The Exhibitors Guidelines state that labels must be typed or professionally printed on white card stock of business card size.
4. Labels are to be attached to the right of the artwork. Artists' putty will be provided. Each label must contain: Title, medium, Artist's name, Selling price, Exhibition number.

Shaker Style Chest of Drawers

Phil Christenson

Recently, Jackson, my son-in-law, and I completed a Shaker style chest of drawers for grandson, Henry, who also helped out. The goal was to build a high quality chest which could last for generations.

With that in mind, we picked the traditional Shaker design by Tom McLaughlin, which in turn, is based on the designs of Thomas. Moser. To increase the odds of a successful build, we purchased the full scale plans and access to on-line videos from Epic Woodworking. Wood movement is a big concern with this design and the videos were of great help in focusing our attention on the small details required to account for wood movement. Cherry was the primary wood with some poplar used in the basic case. The sides and backs of the drawers were made of maple. As you can see, this project used lot of dovetails - many of them cut by hand. By the time the last drawer was

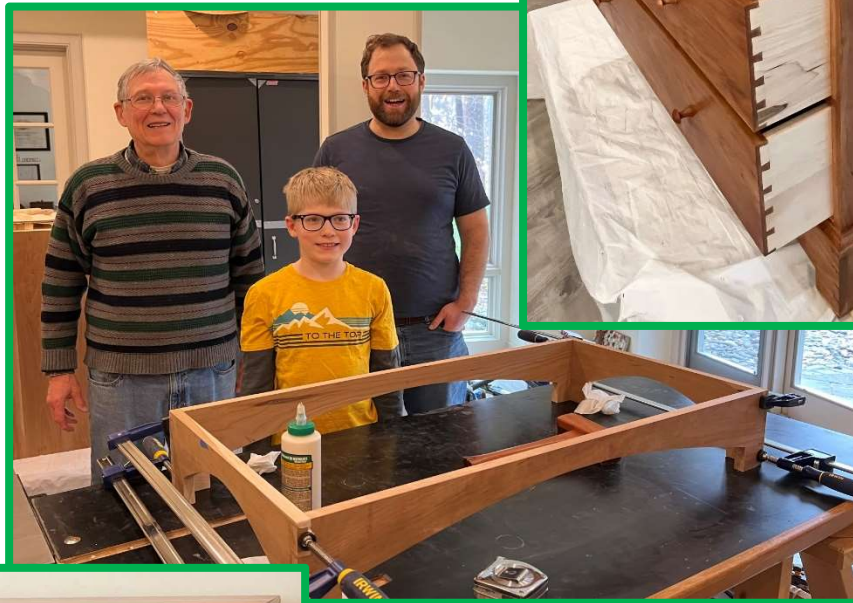

finished, we had become fairly proficient (but not experts) at cutting dovetails. In addition, we learned how to properly make closely fitted drawers.

The chest was sanded to 400 grit - inside and out. The inside of the chest was finished with two coats of shellac and the top, sides, base and drawer fronts were finished with two or three coats of Tried & True (Original). A light topcoat of OSMO wood wax added some sheen to the chest. We were quite pleased with how the finish came out, but be advised that using Tried & True requires more than a bit of patience (slow drying). Overall, this was a great project to learn new woodworking techniques, improve woodworking skills and, most of all, to have an enjoyable experience in working with Jackson & Henry.

Colonial Woodcutter

Woodworking Opportunity - Help Needed

The Guild recently received a letter from Ken Reinhard, owner of Ken Reinhard Design Associates. Some of his products are sold by a company called Artful Home. He designs his pieces, but doesn't build them all. The craftsman who built his plant stand recently retired and Ken wants to know if anyone from our guild would be interested in making these plant stands for him.

He has full-size working drawings for the stand that he will give to you. He also has a stand in his studio (2607 Love Point Road, Stevensville, MD) that you can look at. The stand is made out of solid cherry and stands 36" tall. If you don't have cherry, he may be able to get some for you. It is not a mass-production project. He is looking for someone who can help him out as needed, maybe 2 or 3 times a year.



Ken can be reached at kr@kenreinhard.com, office: 410-643-8063, cell: 410-739-5732. His website is kenreinhard.com. He basically wants to know if anyone is interested in making this stand for him, and how much time (labor) it would take. He will apply the finish. Since we don't have a Special Projects Coordinator yet, let me know if you are interested in this opportunity; but, you will need to reach out to Ken to work out the details and the money.

Thank you,

Ann

443-742-7037

annsentinella@gmail.com

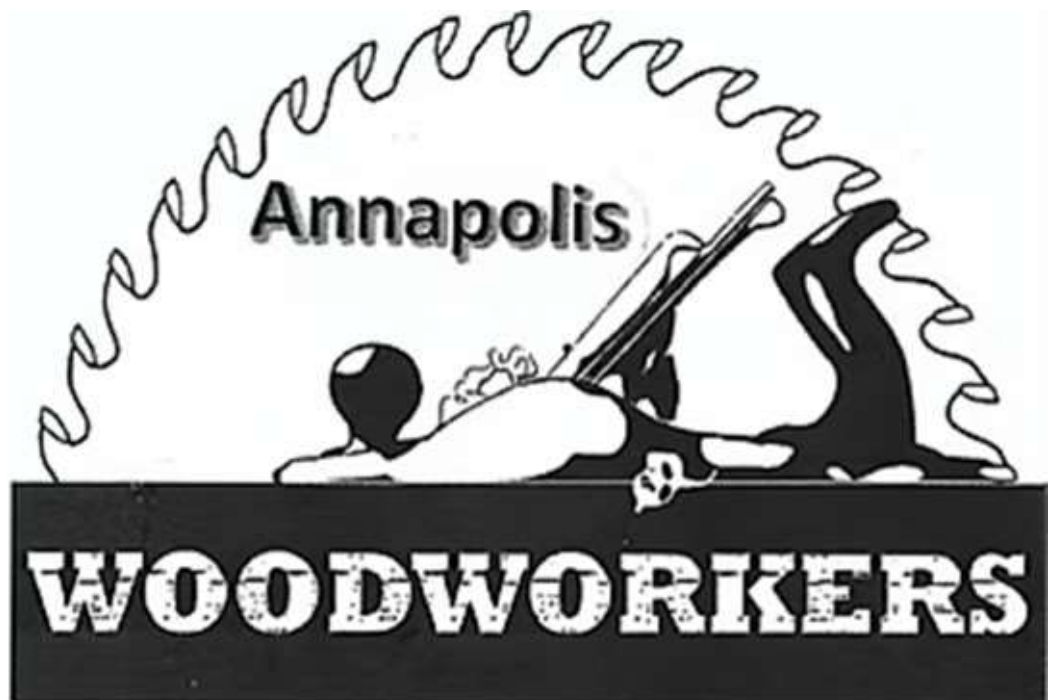

Busch Annapolis Library Hobby Fair

On August 2nd Candee van Iderstine and Paul Hansen set up and staffed an Annapolis Woodworkers Guild table at the Busch Annapolis Library Hobby Fair. They were adjacent to the Annapolis Makerspace's table and enticed people with both the education component and the shop availability of the Makerspace with mentor help and classes from both. Trevor Griffin, who is a member of both groups, was on the Makerspace table staff.

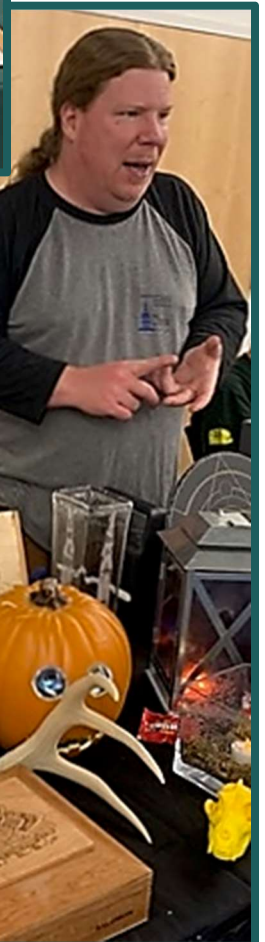

Tip of the Month



Re-Hole Sawing

I recently had a situation where I needed to enlarge a previously drilled hole. Since I couldn't use my hole saw's pilot bit to center the hole, and I don't have a drill press, I had to come up with a solution.

What worked for me was to connect two hole saws together. One was the size of the existing hole. This saw guided the other hole saw that was the size of the hole I needed to drill.

The $\frac{1}{4}$ " pilot bit for my hole saws is held in place with a set screw. So I

removed the bits from both saws and secured a short length of $\frac{1}{4}$ " steel rod between them.

The drawing below and photos above show how I did it. The result was a perfectly centered hole with no fuss.

*Bruce Thompson
Hockessin, Delaware*

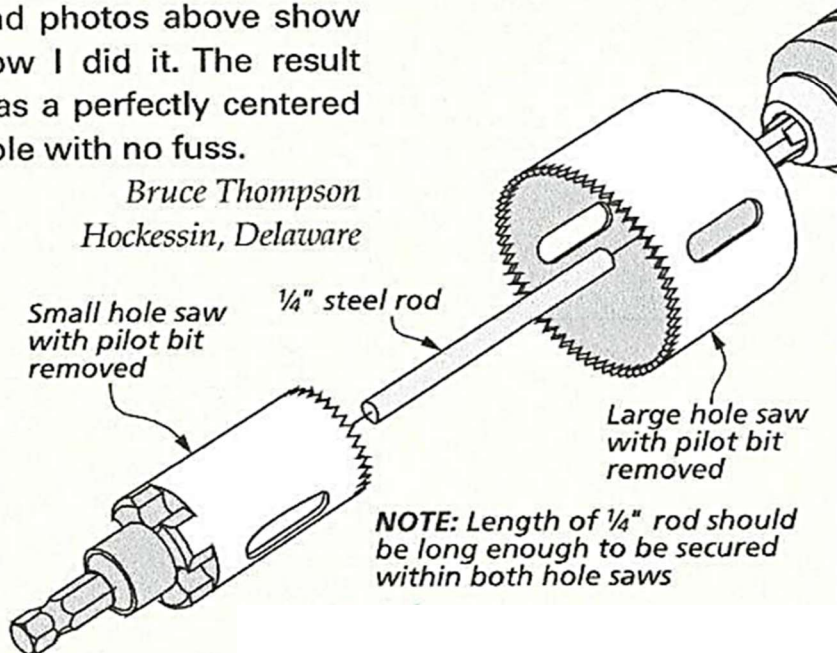

This month's tip is reproduced with the permission of Woodsmith Magazine.

One on One Skills Classes and Instructors

Rick Hodgdon is setting up a program that will enable members to learn woodworking skills from experienced woodworkers in one-on-one settings. If you are interested in learning or improving your skills in the areas listed below, feel free to contact the instructor and schedule a session.

Member/Instructor	Skills	Email address
Rick Hodgdon	Veneering -- Table saw	mattaponiguy@gmail.com
Bill Carbin	Box Making	carbinwilliamj@yahoo.com
Chris Desautels	Chairmaking: Maloof and Windsor	christopher.desautels@gmail.com
Carl Wick	Basic Lathe Skills	cewick70@gmail.com
Bob Ashby	Routers, Shapers & Moulding	toolsrus1958@gmail.com
Paul Dodson	Scroll Saw, Basic woodworking, Shop Safety on any machine	pdwoodcrafts@verizon.net
Harry Chavez	Scroll Saw and Intarsia	harry.chavez@gmail.com
Adam Schmitt	General woodworking	scott@salanwoodbine.com
Dennis Harvey	Pen making	denharv@aol.com
Bill Kovalick	General woodworking / Adirondack furniture	bkovalick@gmail.com
Bill Schneck	Woodworking machine operations & safety, Basic joinery, dovetails mortise and tennon	mrwoodbutcher@comcast.net
Phil Christenson	Handcut dovetails, Tablesaw techniques	machristenson@aol.com

AWG Member Mentors

Want to learn a new skill? AWG has many member-mentors to help you. See the list below to contact one.

Have a vexing woodworking problem? There may be many other members with the same situation. AWG has a “problem box” where you can anonymously place your problem or question for discussion and possible solutions at the next meeting. You will find the box at a table near the meeting hall entrance door (when we are back in session at the church). Until then send your problems to the editor, President, or other AWG officer.

Last Name	First Name	Phone	E-mail	Mentor Subject
Ames	Don	410-268-0509	dfames@verizon.net	Use and maintenance of Edge Tools (planes, chisels, scrapers)
Ashby	Bob	410-969-2910	toolsrus58@comcast.net	Shapers, router tables and tooling for same
Chavez	Harry	410-863-5940	harry.chavez@gmail.com	Intarsia
Dodson	Paul	410-984-8488	pdwoodcrafts@verizon.net	Scroll saws and scrolling
Harvey	Dennis	240-463-4641	denharv@aol.com	Pen making
Hirrlinger	Jack	410-798-1339	tjhirr@verizon.net	Toys, tricks and puzzles
McDonald	Chris	410-326-1685	cmcdonald@thewavaz.com	Cabinets

AWG Officers

(June 2025 —May 2026 Term)

President – Ann Sentinella
1st Vice President – Chris Bucknall
2nd Vice President – James Cowan
Secretary – Tim Wilson
Co-Treasurers – Vince Antonioli and
Rodger Young
Tour Coordinator – Rick Hodgdon and
Rodger Young
Program Committee – Brian Parker, Sue
Springett, Bob Ashby, Art Mensch
and Carl Wick
Newsletter Editor – Duncan Adams

Historian - Open
Endowment Coordinator – Bill Carbin
Entertainment Coordinator – Paul Dodson
Out Reach – Candy Van Iderstine
Show & Tell Coordinator – Bill Carbin
Special Projects Coordinator – Open
Membership Chairperson – Harry Chavez
Charity Coordinator – Andy Borland
Webmaster – Tyler Quevedo
Education Chair – Paul Hansen
Church Liaison – Steve Lund

MEMBERSHIP and MEETINGS

Membership is open to all interested Woodworkers.

Annual Dues: Current members renew dues in January at \$50.

New members added during the course of the calendar year will be assessed dues that are a pro-rata portion of the remainder of the full calendar year during the month joined.

General Membership Meetings:

2nd Thursday of each month 7 PM

Davidsonville United Methodist Church

819 W Central Ave, Davidsonville, MD 21035

Executive Board Meetings:

4th Thursday of the Month at 7 PM

By phone/video until further notice

All are welcome at board meetings

Contact a board member for invitation

CONTACT INFORMATION

Correspondence:

Annapolis Woodworkers Guild

P.O. Box 6001

Annapolis, MD 21401

Website:

Annapoliswoodworkers.org

AWG's Supporting Vendors



Exotic Lumber Company

1610 Whitehall Road, Annapolis, MD 21409
410-349-1705 WWW.Exoticlumber.com



Rockler Woodworking & Hardware

12975 Fair Lakes Shopping Center Ste 2975
Fairfax, VA 22033
571-435-8030
<https://www.rockler.com/retail/stores/va/fairfax-store>



Somerset Door and Column Company

174 Sagamore Street, Somerset, PA 15501
800-242-7916 WWW.Doorandcolumn.com



Klingspor

2555 Tate Boulevard Southeast, Hickory, NC 28603
800-645-5555 WWW.Klingspor.com



American Woodcrafters Supply

212 East Main, Box G, Riceville, IA 50466
800-995-4032 WWW.Americanwoodcrafterssupply.com



Bruso Hardware LLC
67-69 Greylock Avenue
Belleville, NJ 07109
212-337-8510 WWW.Brusso.com



Lake Erie Toolworks
1234 Irwin Drive, Erie, PA 16505
815-528-4337
WWW.LakeErieToolworks.com/Pages/Club
10% Online Discount Code: **AWG10**



Würth Wood Group
6660 Santa Barbara Road
Elkridge, MD 21075
410-796-7600
WWW.Wurthwoodgroup.com



Hartville Tools
Hartville, OH
800-345-2396
WWW.Hartvilletool.com

MARYLAND SELECT HARDWOODS
7470 Mason Springs Road, La Plata, Maryland
301-743-2225 Dennis.Woodruffi@gmail.com

Timberline Farms Sawmill
Arnold Sewell, owner/operator
13000 Old Frederick Rd, Sykesville, MD
Phone (410) 707-0158